



REVERBERATION CHAMBER SOLUTIONS FOR EMC MEASUREMENTS

BEYOND MEASURE.™

 **ETS·LINDGREN**[®]
An ESCO Technologies Company

ETS-LINDGREN IS THE EXPERT IN REVERBERATION CHAMBER SOLUTIONS

SMART™ TECHNOLOGY PROVIDES ADVANCED EMC TESTING SOLUTIONS

The SMART series of reverberation chambers are used primarily for evaluating the emissions and immunity of electronic devices in the frequency range from 80 MHz to 40 GHz. Compared with other test methods, SMART chambers offer the advantages of lower cost, higher field-to-input power ratios and the ability to accommodate large test systems. This chamber can be used for both full and pre-compliance testing including:

- MIL-STD-461F/G
- ISO 11452-11
- GMW3097GS
- EUROCAE ED90
- IEC 61000-4-21
- RTCA DO-160F/G
- SAE J551/16
- SAE J1113/27
- SE Testing
- DEF STAN 59-41
- FORD FMC 1278

ETS-Lindgren SMART (Statistical Mode Averaging Reverberation Test-Site) reverberation chambers use the latest developments in proven reverberation technology and experienced chamber construction to create a superb electromagnetic environment (EME) for EMC testing. SMART chambers operate by using their interior surfaces to reflect internally radiated RF fields. One or more rotating paddles, or tuners, are used to change the cavity boundary conditions. This creates fields having statistical isotropy and field homogeneity over a large working volume. Due to recent advances in reverberation statistical theory, the field measured at one position can be used to predict the maximum field at any other position. Mode stirred (continuous rotation) measurements can also be performed in the chamber where permitted by the test standard. ETS-Lindgren's tuner design ensures fast settling times and maximum throughput during mode tuned testing.

Reverberation chambers have inherent properties of isotropy and homogeneity when suitably excited and stirred which provides several unique features for EMC testing. Assuming proper configuration and a given uncertainty level, field measurement results will be the same regardless of where in the test volume they are taken. Furthermore, reconfiguration of the DUT (Device Under Test) will have minimal effect on those measurements; DUT measurements made between one or more chambers will be the same within the uncertainty of the system. The benefits are excellent measurement repeatability and test result reproducibility.

Adding to the appeal of reverberation chambers is that robust field strengths can be generated using less power than required by other test environments. The benefit is that less expensive amplifiers can be used without sacrificing performance. Reverberation chambers subject the DUT to multiple polarities and incidence angles simultaneously during a test; hence, they are well suited to simulating the complex EM environment of cavities such as computer rooms, medical equipment rooms, aircraft avionics bays and vehicle engine compartments.

TYPICAL SMART 80 REVERBERATION CHAMBER TEST SETUP

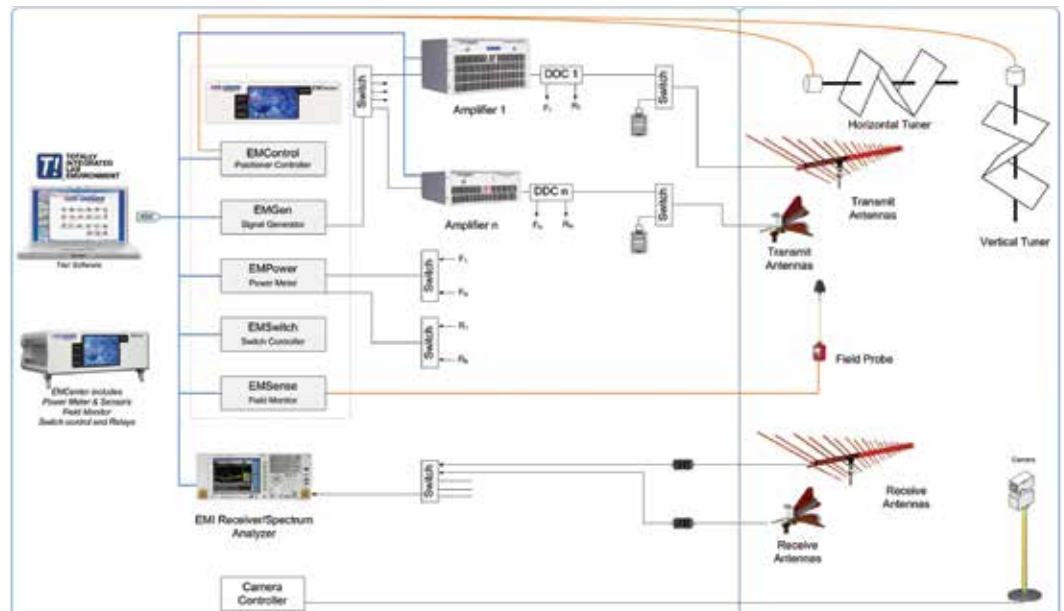



SMART REVERBERATION MEASUREMENT TEST SPECIFICATIONS

TYPICAL CONFIGURATION

ETS-Lindgren understands reverberation chamber technology and can design and customize a chamber to meet your exact needs. Lining materials are selected from galvanized steel, aluminum or copper with different loss characteristics. Below please find a typical configuration for our SMART 80 chamber.

SMART 80 Physical Specifications

Item	Description
RF Shielding	Modular RF Shielded Enclosure – Inside Shield Dimensions: 13.41 m x 6.10 m x 4.88 m (44.0 ft x 22.0 ft x 16.0 ft) – Estimated Overall Dimensions: 13.87 m x 6.65 m x 5.41 m (45.5 ft x 21.83 ft x 17.75 ft)
RF Shielded Door	ETS-Lindgren RFDD-60 Manual Dual-leaf Swing Door, 1.8 m x 2.1 m (6.0 ft x 7.0 ft)
Equipment	Z-fold Aluminum Paddles and Mounting Shafts to Include: – One Nominal 152.4 cm x 152.4 cm x 6.1 m (60 in x 60 in x 20 ft) – One Nominal 152.4 cm x 152.4 cm x 4.88 m (60 in x 60 in x 16 ft) – Two Model 3117 Double-ridged Waveguide Horn Antennas, 1 GHz to 18 GHz – Two Model 3144 Log Periodic Antennas, 80 MHz to 2 GHz – Three Ceiling Mounts for Log Periodic and Horn Antennas – One Wall Mount for Horn Antennas – TILE!™ (Total Integrated Lab Environment) Software Package

ADDITIONAL SMART CHAMBERS

SMART 100

8.4 m x 5.6 m x 3.1 m (27.6 ft x 18.4 ft x 10.0 ft)
Includes One Z4848 Tuner

SMART 200

4.8 m x 3.5 m x 3.1 m (15.7 ft x 11.5 ft x 10.0 ft)
Includes One Z3030 Tuner

SMART 700

2.0 m x 1.2 m x 1.3 m (6.6 ft x 3.9 ft x 4.3 ft)
Includes One Z1515 Tuner

SMART 800/1000

1.5 m x 1.0 m x 0.8 m (4.9 ft x 3.3 ft x 2.6 ft)
Includes Two Z0808 Tuners

Sales and Support Offices

UNITED STATES – TEXAS

Cedar Park, TX
+1.512.531.6400 Phone
+1.512.531.6500 Fax
info@ets-lindgren.com

UNITED STATES – ILLINOIS

Wood Dale, IL
+1.630.307.7200 Phone
+1.630.307.7571 Fax
info@ets-lindgren.com

UNITED STATES – WISCONSIN

Minocqua, WI
+1.715.356.2022 Phone
+1.715.356.2023 Fax
info@ets-lindgren.com

FINLAND

Eura
+358.2.8383.300 Phone
+358.2.8651.233 Fax
euinfo@ets-lindgren.com

UNITED ARAB EMIRATES

Dubai
+971.55.610.4055 Phone
uae@ets-lindgren.com

CHINA

Beijing
+86(10)8273.0877 Phone
+86(10)8273.0880 Fax
china@ets-lindgren.com

JAPAN

Tokyo
+81.3.3813.7100 Phone
+81.3.3813.8068 Fax
japan@ets-lindgren.com

INDIA

Bangalore
+91.80.4341.8600 Phone
+91.80.4341.8611 Fax
indiainfo@ets-lindgren.com

SINGAPORE

Singapore
+65.6391.0026 Phone
+65.6291.7311 Fax
singapore@ets-lindgren.com

TAIWAN

Taipei
+886.2.27023389 Phone
+886.2.27023055 Fax
taiwan@ets-lindgren.com

BEYOND MEASURE.



An ESCO Technologies Company

ets-lindgren.com